

**UNITED STATES DISTRICT COURT
NORTHERN DISTRICT OF ILLINOIS
EASTERN DIVISION**

PUFFIN COOLERS, LLC,

Plaintiff,

v.

THE PARTNERSHIPS AND
UNINCORPORATED ASSOCIATIONS
IDENTIFIED IN SCHEDULE "A",

Defendants.

No. 21-cv-5655

DEMAND FOR JURY TRIAL

COMPLAINT

Puffin Coolers, LLC ("Plaintiff"), by and through its undersigned counsel, hereby files this Complaint for trademark infringement under the Lanham Act, offering for sale and selling counterfeit goods in violation of Plaintiff's exclusive rights, design patent infringement, copyright infringement, violations of the Illinois Deceptive Trade Practices Act, and civil conspiracy against the Partnerships and Unincorporated Associations Identified in Schedule "A" (together, "Defendants"). In support hereof, Plaintiff states as follows:

I. JURISDICTION AND VENUE

1. This Court has original subject matter jurisdiction over the claims in this action pursuant to the provisions of the Lanham Trademark Act, 15 U.S.C. § 1051, et seq., the Patent Act, 35 U.S.C. § 1, et seq., the Federal Copyright Act, 17 U.S.C. § 101, et seq, 28 U.S.C. § 1338(a)-(b) and 28 U.S.C. § 1331. This Court has jurisdiction over the claims in this action that arise under the laws of the State of Illinois pursuant to 28 U.S.C. § 1367(a) because the state law claims are so related to the federal claims that they form part of the same case or controversy and derive from a common nucleus of operative facts.

2. Venue is proper in this Court pursuant to 28 U.S.C. § 1391, and this Court may properly exercise personal jurisdiction over Defendants, since each Defendant directly targets business activities toward consumers in the United States, including Illinois, through their operation of or assistance in the operation of the fully interactive, commercial internet stores operating under the Defendant domain names and/or the Defendant Internet Stores identified in Schedule A. Specifically, each of the Defendants directly reaches out to do business with Illinois residents by operating or assisting in the operation of one or more commercial, interactive e-commerce stores that sell products using counterfeit versions of Plaintiff's federally registered trademarks directly to Illinois consumers. In short, each Defendant is committing tortious acts in Illinois, is engaging in interstate commerce, and has wrongfully caused Plaintiff substantial injury in the State of Illinois.

II. INTRODUCTION

3. Plaintiff filed this action to combat online infringers and counterfeiters who trade upon Plaintiff's reputation and goodwill by selling and/or offering for sale unauthorized and unlicensed counterfeit and infringing products using counterfeit versions of Plaintiff's federally registered trademarks PUFFIN (U.S. Reg. No. 5,878,014) and FUN.TOGETHER. (U.S. Reg. No. 6,575,416) (the "PUFFIN Trademarks"), and/or by making, using, offering for sale, selling and/or importing into the United States for subsequent sale or use unauthorized and unlicensed product that infringe Puffin Coolers, LLC's patented designs (U.S. Reg. Nos. US D940,509 S and US D946,353 S) (the "PUFFIN Designs"), and/or by using Plaintiff's copyrighted photographs and texts (U.S. Reg. Nos. VA0002314760 and TXU002329856) (the "PUFFIN Works") in connection with the sale and advertising of the infringing products, attached as **Group Exhibit 1**. The Defendants created internet stores (the "Defendant Internet Stores" or the "Stores") by the dozens

and designed them to appear to be selling genuine copies of Plaintiff's PUFFIN and FUN.TOGETHER. branded products when in fact the Stores are selling counterfeit versions to unknowing customers, and/or making, using, offering for sale, selling, and/or importing into the United States for subsequent sale or use infringing products to unknowing consumers.

4. The Defendant Internet Stores share unique identifiers, such as similar design elements of the infringing product offered for sale and, on information and belief, these similarities suggest that the Defendant Internet Stores share common manufacturing sources, thus establishing the Defendants' counterfeiting and infringing operations arise out of the same transaction, occurrence, or series of transactions or occurrences. Defendants have gone to great lengths to avoid liability by concealing both their identities and the full scope and interworking of their counterfeiting operation, including changing the names of their Stores multiple times, opening new Stores, helping their friends open Stores, and making subtle changes to their products. Plaintiff has been forced to file this action to combat Defendants' willful infringement of Plaintiff's registered trademarks, patented designs, and copyrighted works, as well as to protect unknowing consumers from purchasing infringing products over the internet. Plaintiff has been and continues to be irreparably damaged both through consumer confusion, dilution, and tarnishment of its valuable trademarks as a result of Defendants' actions and seek injunctive and monetary relief, and from loss of its lawful patent rights to exclude others from making, using, selling, offering for sale, and importing its patented designs.

III. THE PARTIES

A. Plaintiff Puffin Coolers, LLC

5. Plaintiff is an Oregon limited liability company and is the creator and seller of a variety of high-quality drinkwear¹ products for keeping canned and bottled beverages insulated (collectively, the “PUFFIN Products”). Plaintiff sells these designs through its brand PUFFIN, which allows the consumers to purchase a variety of container covers with excellent thermal insulation through the company’s e-commerce marketplaces. The PUFFIN Products have become enormously popular and even iconic, driven by Plaintiff’s exacting quality standards and innovative design. Among the purchasing public, genuine PUFFIN Products are instantly recognizable as such. In the United States and around the world, the PUFFIN Trademarks have come to symbolize high quality, and the PUFFIN Products are among the most recognizable drinkwear items in the United States.

6. Plaintiff launched its PUFFIN and FUN.TOGETHER. branded products in 2018 and 2019, respectively, on its own website and its Amazon storefront. Plaintiff’s founder and innovator created the unique PUFFIN designs after finding a need to bring “fun and celebrate good” by creating fabulous drinkwear to keep beverages insulated. Since 2018, Plaintiff has introduced several variations of the PUFFIN Designs through its various e-commerce marketplaces. Plaintiff’s unique products have been advertised with its federally registered trademarks PUFFIN and FUN.TOGETHER. for several years. Plaintiff continues to heavily advertise its unique products on all its e-commerce marketplaces², social media, advertisements, and product demonstration videos to educate consumers on both its products and trademarked

¹ “Drinkwear” refers to the fact that Plaintiff’s products are beverage insulators in the form of miniaturized versions of outerwear and personal flotation devices.

² <https://puffindrinkwear.com/>; https://www.amazon.com/stores/PuffinDrinkwear/page/ED7E2B20-2330-4294-85FC-C8ABE0C1FF84?ref_=ast_bln

name. Its websites and social media feature original content, reviews, and testimonials for the PUFFIN Products.

7. Plaintiff is engaged in the business of manufacturing, distributing, and retailing these high-quality drinkwear products within the Northern District of Illinois under the Federally registered trademarks PUFFIN and FUN.TOGETHER. Defendants' sales of the counterfeit product in violation of Plaintiff's intellectual property rights are irreparably damaging Plaintiff.

8. Plaintiff's brand, symbolized by the PUFFIN Trademarks, is a recognized brand of drinkwear products. The PUFFIN Trademarks are distinctive and identify the merchandise as goods originating from the Plaintiff. The registration for the PUFFIN Trademarks constitutes prima facie evidence of its validity and of Plaintiff's exclusive right to use the PUFFIN Trademarks pursuant to 15 U.S.C. § 1057(b). The PUFFIN Trademarks have been continuously used and never abandoned since their first use.

9. Plaintiff uses the PUFFIN Trademarks to identify its goods. The Trademarks are distinct when they are applied to Plaintiff's goods, signaling to the purchaser and consumer that the products are from Plaintiff and are made and manufactured to Plaintiff's original specifications and standards.

10. Since its initial launch of the original PUFFIN and FUN.TOGETHER. branded products, as of its first use in commerce in 2018 and 2019 respectively, Plaintiff's trademarks have been the subject of substantial and continuous marketing and promotion by the Plaintiff throughout the United States and, due to its strong internet presence, throughout the entire world. Plaintiff has and continues to widely promote and market its trademarks to customers and the general public, and on Plaintiff's website. Genuine and authentic PUFFIN and FUN.TOGETHER. branded products offered and sold by Plaintiff directly through reputable e-commerce marketplaces,

including Amazon.com, Target.com, Wayfair.com, its own website and others, as well as through physical retail stores, including TJ Maxx, Ross, Marshalls, and various boutique stores throughout the United States.

11. Plaintiff has expended substantial time, money, and other resources to develop, advertise, and otherwise promote the PUFFIN Trademarks. As a result, customers recognize that products bearing the distinctive PUFFIN Trademarks originate exclusively from the Plaintiff.

12. The PUFFIN Products are known for their distinctive patented designs. These designs are well-recognized by consumers. Drinkwear fashioned after these designs are associated with the quality and innovation that the public has come to expect from the PUFFIN Products. Plaintiff uses these designs in connection with its PUFFIN branded products, including, but not limited to, the following patented designs.

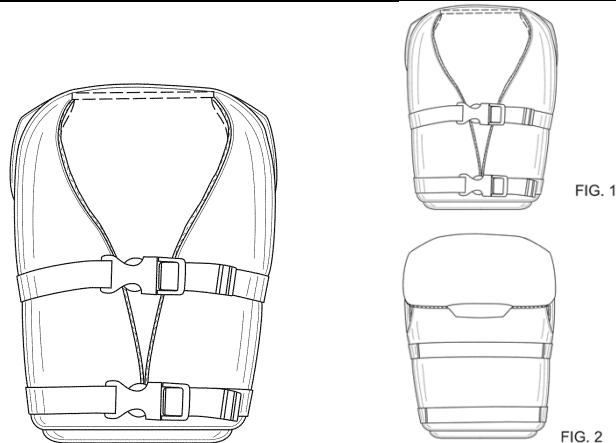
Patent Number	Claim	Issue Date
US D940,509 S		January 11, 2022

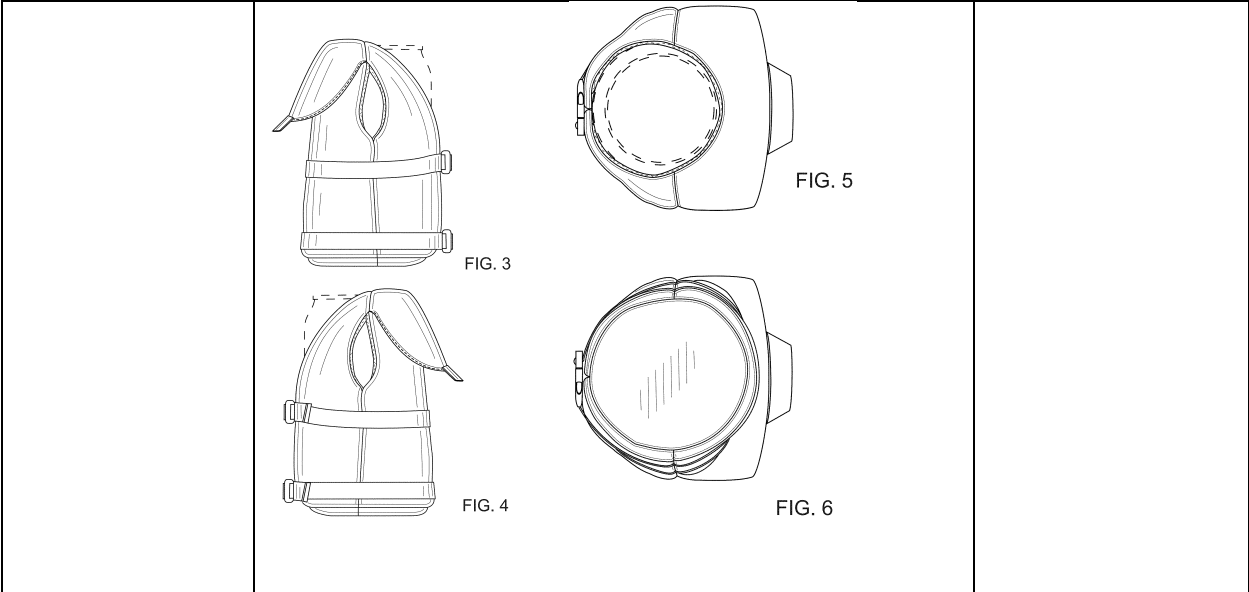

US D946,353 S

March 22, 2022

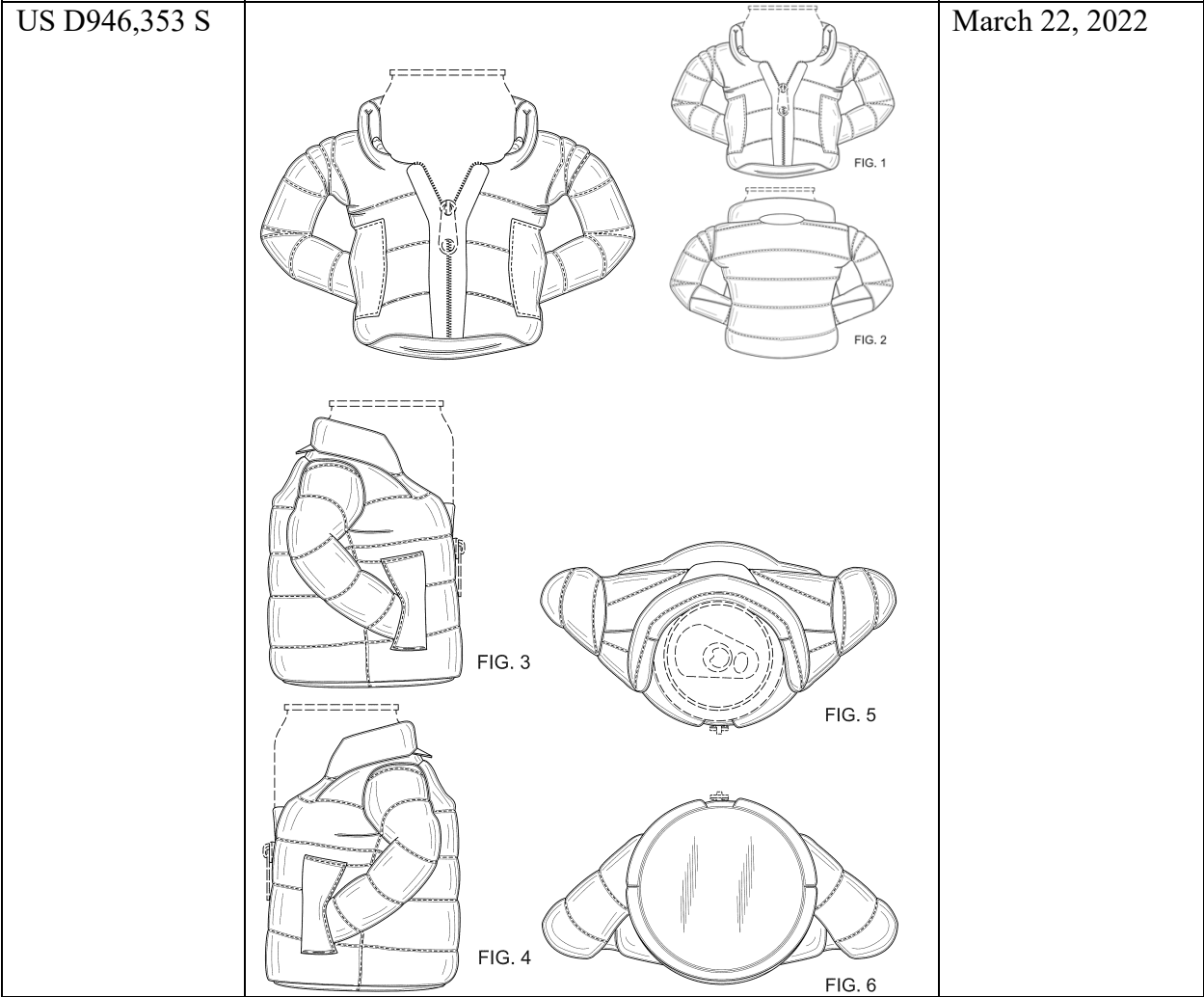

13. Puffin Coolers, LLC is the lawful assignee of all right, title, and interest in and to the PUFFIN Designs. US Patent No. US D940,509 S (the “509 Patent”) was lawfully issued on January 11, 2022, with the named inventors Tyrone Hugh Hazen, Byron Jay Linton, Jr., and Christina Joy Linton. US Patent No. US D946,353 S (the “353 Patent”) was lawfully issued on March 22, 2022, with the named inventors Tyrone Hugh Hazen, Byron Jay Linton, Jr., and Christina Joy Linton.

14. Plaintiff is also the owner of United States Copyright Registration U.S. Reg. Nos. VA0002314760 and TXU002329856. Upon information and belief, the copyrights have an effective date that predates the Defendants’ acts of copyright infringement.

The Defendants

15. Defendants are individuals and entities who, upon information and belief, reside in the People’s Republic of China or other foreign jurisdictions. Defendants conduct business throughout the United States, including within the state of Illinois and in this Judicial District, through the operation of fully interactive commercial websites and online commercial marketplaces operating under the Defendant Internet Stores. Each Defendant targets the United States, including Illinois, and has offered to sell and, on information and belief, has sold and continues to sell infringing products to consumers within the United States, including Illinois and in this Judicial District.

16. Defendants are an interrelated group of infringers and counterfeiters who create numerous Defendant Internet Stores and design these stores to appear to be selling genuine PUFFIN branded products, while they actually sell inferior imitations of Plaintiff’s PUFFIN branded products, and/or to knowingly and willfully manufacture, import, distribute, offer for sale, and sell infringing products. The Defendant Internet Stores share unique identifiers, such as

common design elements, the same or similar counterfeit products that they offer for sale, similar counterfeit product descriptions, the same or substantially similar shopping cart platforms, accepted payment methods, check-out methods, lack of contact information, and identically or similarly priced counterfeit products and volume sale discounts. As such, the Defendant Internet Stores establish a logical relationship between them and suggest that Defendants' illegal operations arise out of the same transaction or occurrence. The tactics used by Defendants to conceal their identities and the full scope of their counterfeiting operation make it virtually impossible for Plaintiff to learn the precise scope and the exact interworking of their counterfeit network. If Defendants provide additional credible information regarding their identities, Plaintiff will take appropriate steps to amend the Complaint.

IV. THE DEFENDANTS' UNLAWFUL CONDUCT

17. The success of Plaintiff's brand has resulted in significant infringement and counterfeiting. Consequently, Plaintiff has identified numerous marketplace listings on eCommerce platforms such as, but not limited to, Alibaba, AliExpress, Amazon, Dhgate, eBay, Etsy, Joom, Shopify, Walmart, and Wish, which include the Defendant Aliases and which have been offering for sale, completing sales, and exporting illegal products to consumers in this Judicial District and throughout the United States. Defendants have persisted in creating the Defendant Aliases. E-commerce sales, including e-commerce internet stores like those of Defendants, have resulted in a sharp increase in the shipment of unauthorized products into the United States. See **Exhibit 2**, Department of Homeland Security, *Fiscal Year 2019 Seizure Statistics Report*. According to Customs and Border Patrol's ("CBP") report, over 90% of all CBP intellectual property seizures were smaller international mail and express shipments (as opposed to large shipping containers). *Id.* Approximately 85% of CBP seizures originated from mainland

China and Hong Kong. *Id.* Counterfeit and pirated products account for billions of dollars in economic losses, resulting in tens of thousands of lost jobs for legitimate businesses and broader economic losses, including lost tax revenue.

18. Counterfeiting rings take advantage of the anonymity provided by the internet, which allows them to evade enforcement efforts to combat counterfeiting. For example, counterfeiters take advantage of the fact that marketplace platforms do not adequately subject new sellers to verification and confirmation of their identities, allowing counterfeiters to “routinely use false or inaccurate names and addresses when registering with these Internet platforms.” *See Exhibit 3*, Daniel C.K. Chow, *Alibaba, Amazon, and Counterfeiting in the Age of the Internet*, 41 *Nw. J. Int’l. L. & Bus.* 24 (2020). Additionally, “Internet commerce platforms create bureaucratic or technical hurdles in helping brand owners to locate or identify sources of counterfeits and counterfeiters.” *Id.* at 25. Therefore, with the absence of regulation, Defendants may and do garner sales from Illinois residents by setting up and operating e-commerce internet stores that target United States consumers using one or more aliases, offer shipping to the United States, including Illinois, accept payment in U.S. dollars, and, on information and belief, have sold counterfeit products to residents of Illinois.

19. Upon information and belief, at all times relevant hereto, the Defendants in this action have had full knowledge of Plaintiff’s ownership of the PUFFIN design patents, copyrights, and trademarks, including its exclusive right to use and license such intellectual property and their associated goodwill. Defendants’ Internet Stores also use the same pictures to advertise their infringing product that Plaintiff uses on its webpage and other online marketplaces to sell and advertise its genuine and original PUFFIN Products, sowing further confusion among potential purchasers.

20. Defendants go to great lengths to conceal their identities by using multiple fictitious names and addresses to register and operate their massive network of Defendant Internet Stores. Other Defendant domain names often use privacy services that conceal the owners' identity and contact information. Upon information and belief, Defendants regularly create new websites and online marketplace accounts on various platforms using the identities listed in Schedule A of this Complaint, as well as other unknown fictitious names and addresses. Such Defendant Internet Store registration patterns are one of the many common tactics used by the Defendants to conceal their identities, the full scope and interworking of their massive counterfeiting operation, and to avoid being shut down.

21. The infringing products for sale in the Defendant Internet Stores bear similarities and indicia of being related to one another, suggesting that the infringing products were manufactured by and come from a common source and that, upon information and belief, Defendants are interrelated.

22. Upon information and belief, Defendants also deceive unknowing customers by using the PUFFIN Trademarks without authorization within the content, text, and/or metatags of their websites and marketplace storefronts to attract various search engines on the Internet looking for websites relevant to consumer searches for Plaintiff's PUFFIN and FUN.TOGETHER. branded products. Additionally, upon information and belief, Defendants use other unauthorized search engine optimization tactics and social media spamming so that the Defendant Internet Stores listings show up at or near the top of relevant search results after others are shut down. As such, Plaintiff also seeks to disable Defendant domain names owned by Defendants that are the means by which the Defendants could continue to sell counterfeit products.

23. Defendants' use of the PUFFIN Works and Trademarks on or in connection with the advertising, marketing, distribution, offering for sale, and sale of the infringing products is likely to cause and has caused confusion, mistake, and deception by and among consumers and is irreparably harming Plaintiff.

24. Defendants, without authorization or license from Plaintiff, knowingly and willfully used and continue to use the PUFFIN Works and Trademarks in connection with the advertisement, offer for sale, and sale of the counterfeit products, through, inter alia, the internet. The infringing products are not PUFFIN and FUN.TOGETHER. branded products of the Plaintiff. Plaintiff did not manufacture, inspect, or package the infringing products and did not approve the counterfeit products for sale or distribution. Each of the Defendants' Internet Stores offers shipping to the United States, including Illinois, and, on information and belief, each Defendant has sold counterfeit products into the United States, including Illinois.

25. Defendants' use of the PUFFIN Works and Trademarks in connection with the advertising, distribution, offer for sale, and sale of infringing products, including the sale of infringing products into Illinois, is likely to cause and has caused confusion, mistake, and deception by and among consumers and is irreparably harming Plaintiff.

26. Upon information and belief, Defendants are an interrelated group of infringers working in active concert to knowingly and willfully manufacture, import, distribute, offer for sale, and sell Infringing Products in the same transaction, occurrence, or series of transactions or occurrences. Defendants, without any authorization or license from Plaintiff, have jointly and severally, knowingly and willfully offered for sale, sold, and/or imported into the United States for subsequent resale or use products that directly and/or indirectly infringe the Puffin Designs. Each e-commerce store operating under the Seller Aliases offers shipping to the United States,

including Illinois, and, on information and belief, each Defendant has sold Infringing Products in the United States and Illinois over the Internet.

27. Defendants' infringement of the Puffin Designs in making, using, offering for sale, selling, and/or importing into the United States for subsequent sale or use of the Infringing Products was willful.

28. Defendants' infringement of the Puffin Designs in connection with making, using, offering for sale, selling, and/or importing into the United States for the subsequent sale or use of the Infringing Products, including the making, using, offering or sale, selling, and/or importing into the United States for the subsequent sale or use of Infringing Products into Illinois, is irreparably harming Plaintiff.

29. Upon information and belief, Defendants will continue to register or acquire listings for the purpose of selling infringing products that infringe upon the PUFFIN design patents, copyrights, and trademarks unless preliminarily and permanently enjoined.

COUNT I

TRADEMARK INFRINGEMENT AND COUNTERFEITING (15 U.S.C. § 1114)

30. Plaintiff hereby realleges and incorporates by reference the allegations set forth in paragraphs 1 through 29.

31. This is a trademark infringement and counterfeit action against Defendants based on their unauthorized use in commerce of counterfeit imitations of the federally registered PUFFIN and FUN.TOGETHER. trademarks in connection with the sale, offering for sale, distribution, and/or advertising of infringing goods. The PUFFIN trademarks are distinctive marks. Consumers have come to expect the highest quality from Plaintiff's products provided under Plaintiff's trademarks.

32. Defendants have sold, offered to sell, marketed, distributed, and advertised, and are still selling, offering to sell, marketing, distributing, and advertising products in connection with Plaintiff's Trademarks without Plaintiff's permission.

33. Plaintiff is the exclusive owner of Plaintiff's trademarks. Plaintiff's United States Registrations for Plaintiff's trademarks (**Exhibit 1**) are in full force and effect. Upon information and belief, Defendants have knowledge of Plaintiff's rights in Plaintiff's trademarks and are willfully infringing and intentionally using counterfeit items of Plaintiff's trademarks. Defendants' willful, intentional, and unauthorized use of Plaintiff's trademarks is likely to cause confusion, mistake, and deception as to the origin and quality of the counterfeit goods among the general consuming public.

34. Defendants' activities constitute willful trademark infringement and counterfeiting under Section 32 of the Lanham Act, 15 U.S.C. § 1114.

35. Plaintiff has no adequate remedy at law, and if Defendants' actions are not enjoined, Plaintiff will continue to suffer irreparable harm to its reputation and the goodwill of its well-known trademarks.

36. The injuries sustained by Plaintiff have been directly and proximately caused by Defendants' wrongful reproduction, use, advertisement, promotion, offer to sell, and sale of counterfeit versions of Plaintiff's PUFFIN and FUN.TOGETHER. branded products.

COUNT II

FALSE DESIGNATION OF ORIGIN (15 U.S.C. § 1125)

37. Plaintiff hereby realleges and incorporates by reference the allegations set forth in paragraphs 1 through 36.

38. Defendant's promoting, marketing, offering for sale, and selling of infringing and counterfeit products has created and is creating a likelihood of confusion, mistake, and deception among the general public as to the affiliation, connection, or association with Plaintiff or the origin, sponsorship, or approval of Defendants' counterfeit version of Plaintiff's unique PUFFIN branded products.

39. By using Plaintiff's trademarks in connection with the sale of counterfeit products, Defendants create a false designation of origin and a misleading representation of the fact as to the origin and sponsorship of the counterfeit product. By their use of Plaintiff's original photographs and texts in association with the offer and sale of the counterfeit product, Defendants seek to further confuse the relevant public as to the source or sponsorship of their goods by Plaintiff.

40. Defendants' false designation of origin and misrepresentation of fact as to the origin and/or sponsorship of the counterfeit product to the general public is a willful violation of Section 43 of the Lanham Act, 15 U.S.C. § 1125.

41. Plaintiff has no adequate remedy at law and, if Defendants' actions are not enjoined, Plaintiff will continue to suffer irreparable harm to its reputation and the goodwill of its brand.

COUNT III

VIOLATION OF ILLINOIS UNIFORM DECEPTIVE TRADE PRACTICES ACT (815 ILCS § 510/1, *et seq.*)

42. Plaintiff hereby realleges and incorporates by reference the allegations set forth in paragraphs 1 through 41.

43. Defendants have engaged in acts violating Illinois law including, but not limited to, passing off their counterfeit product as those of Plaintiff, causing a likelihood of confusion and/or misunderstanding as to the source of their goods, causing a likelihood of confusion and/or misunderstanding as to an affiliation, connection, or association with Plaintiff's genuine and

authentic PUFFIN branded products, representing that their products have Plaintiff's approval when they do not, and engaging in other conduct which creates a likelihood of confusion or misunderstanding among the public.

44. The foregoing Defendants' acts constitute a willful violation of the Illinois Uniform Deceptive Trade Practices Act, 815 ILCS § 510/1, *et seq.*

45. Plaintiff has no adequate remedy at law, and Defendants' conduct has caused Plaintiff to suffer damage to its reputation and goodwill. Unless enjoined by this Court, Plaintiff will suffer future irreparable harm as a direct result of Defendants' unlawful activities.

COUNT IV

INFRINGEMENT OF UNITED STATES DESIGN PATENTS (35 U.S.C. §271)

46. Plaintiff hereby realleges and incorporates by reference the allegations set forth in paragraphs 1 through 45.

47. Plaintiff is the lawful assignee of all right, title, and interest in and to the PUFFIN Designs (U.S. Reg. Nos. US D940,509 S and US D946,353 S). *See, Exhibit 1.*

48. Defendants are making, using, offering for sale, selling, and/or importing into the United States for subsequent sale or use Infringing Products that infringe directly and/or indirectly the ornamental design claimed in the Plaintiff's Design Patents.

49. Defendants have been and are infringing Plaintiff's Design Patents by making, using, selling, or offering for sale in the United States, or importing into the United States, including within this judicial district, the accused products in violation of 35 U.S.C. § 271(a).

50. Defendants have infringed Plaintiff's Design Patents through the aforesaid acts and will continue to do so unless enjoined by this Court. Defendants' wrongful conduct has caused Plaintiff to suffer irreparable harm resulting from the loss of its lawful patent rights to exclude

others from making, using, selling, offering for sale, and importing the patented invention. Plaintiff is entitled to injunctive relief pursuant to 35 U.S.C. § 283.

51. Defendants have infringed Plaintiff's Design Patents because in the eye of an ordinary observer, giving such attention as a purchaser usually gives, the ornamental designs of Plaintiff's Design Patents and the overall design features of Defendants' products are substantially the same, if not identical, with resemblance such as to deceive an ordinary observer, inducing such observer to purchase and Infringing Product supposing to be Plaintiff's product protected by Plaintiff's Design Patents.

52. Plaintiff is entitled to recover damages adequate to compensate for the infringement, including Defendant's profits pursuant to 35 U.S.C § 289. Plaintiff is entitled to recover any other damages as appropriate pursuant to 35 U.S.C. § 284.

COUNT V

COPYRIGHT INFRINGEMENT (17 U.S.C. § 501(a))

53. Plaintiff hereby realleges and incorporates by reference the allegations set forth in paragraphs 1 through 52.

54. Plaintiff's works have significant value and have been produced and created at considerable expense. Plaintiff is the owner of each original work, and all works at issue have been registered with the U.S. Copyright Office. *See, Exhibit 1.*

55. Plaintiff, at all relevant times, has been the holder of the pertinent exclusive rights infringed by Defendants, as alleged hereunder, including but not limited to the copyrighted Plaintiff's works, including derivative works.

56. Upon information and belief, Defendants had access to the works through Plaintiff's normal business activities. After accessing Plaintiff's works, Defendants wrongfully

created copies of the copyrighted Plaintiff's works without Plaintiff's consent and engaged in acts of widespread infringement through publishing and distributing the Plaintiff's works via online websites and digital markets in connection with the marketing of their counterfeit products. Indeed, every photograph and text used by Defendants is virtually identical to the original Plaintiff's works.

57. Plaintiff is informed and believes and thereon alleges that Defendants further infringed Plaintiff's copyrights by making or causing to be made derivative works from Plaintiff's works by producing and distributing reproductions without Plaintiff's permission.

58. Defendants, without the permission or consent of Plaintiff, have published online infringing derivative works of Plaintiff's works. Defendants have violated Plaintiff's exclusive rights of reproduction and distribution. Defendants' actions constitute an infringement of Plaintiff's exclusive rights protected under the Copyright Act (17 U.S.C. § 101, et seq.).

59. Further, as a direct result of the acts of copyright infringement, Defendants have obtained direct and indirect profits they would not otherwise have realized but for their infringement of the copyrighted Plaintiff's works. Plaintiff is entitled to disgorgement of Defendants' profits directly and indirectly attributable to their infringement of Plaintiff's works.

60. The foregoing acts of infringement constitute a collective enterprise of shared, overlapping facts, and have been willful, intentional, and in disregard of and with indifference to the rights of Plaintiff.

61. As a result of Defendants' infringement of Plaintiff's exclusive rights under its copyright, Plaintiff is entitled to relief pursuant to 17 U.S.C. § 504.

62. The conduct of Defendants is causing and, unless enjoined and restrained by this Court, will continue to cause Plaintiff great and irreparable injury that cannot fully be compensated

or measured in money. Plaintiff has no adequate remedy at law. Pursuant to 17 U.S.C. §§ 502 and 503, Plaintiff is entitled to injunctive relief prohibiting Defendants from further infringing Plaintiff's copyrights and ordering that Defendants destroy all unauthorized copies. Defendants' copies, digital files, and other embodiments of Plaintiff's Works from which copies can be reproduced should be impounded and forfeited to Plaintiff as instruments of infringement, and all infringing copies created by Defendants should be impounded and forfeited to Plaintiff, under 17 U.S.C. § 503.

COUNT VI

CIVIL CONSPIRACY

63. Plaintiff hereby realleges and incorporates by reference the allegations set forth in paragraphs 1 through 62.

64. Plaintiff is informed and believes and thereon alleges that Defendants knowingly and voluntarily entered into a scheme and agreement to engage in a combination of unlawful acts and misconduct including, without limitation, a concerted and collaborated effort to maintain the distribution, marketing, advertising, shipping, offer for sale, or sale of counterfeit products in violation of the Illinois Uniform Deceptive Trade Practices Act, 815 ILCS § 510, et seq.

65. The intent, purpose, and objective of the conspiracy and the underlying combination of unlawful acts and misconduct committed by the Defendants was to undermine Plaintiff and its business by unfairly competing against it as described above.

66. The Defendants each understood and accepted the foregoing scheme and agreed to do their respective part, to further accomplish the foregoing intent, purpose, and objective. Thus, by entering the conspiracy, each Defendant has deliberately, willfully, and maliciously permitted, encouraged, and/or induced all the foregoing unlawful acts and misconduct.

67. As a direct and proximate cause of the unlawful acts and misconduct undertaken by each Defendant in furtherance of the conspiracy, Plaintiff has sustained, and unless each Defendant is restrained and enjoined, will continue to sustain severe, immediate, and irreparable harm, damage, and injury for which Plaintiff has no adequate remedy at law.

PRAYER FOR RELIEF

WHEREFORE, Plaintiff prays for judgment against Defendants as follows:

A. That Defendants, their affiliates, officers, agents, servants, employees, attorneys, confederates, and all other persons acting for, with, by, through, under, or in active concert with them be temporarily preliminary, and permanently enjoined and restrained from:

i. Using Plaintiff's trademarks in any manner in connection with the distribution, marketing, advertising, offering for sale, or sale of any product that is not a genuine product of Plaintiff, or is not authorized by Plaintiff to be sold in connection with Plaintiff's trademarks;

ii. Passing off, inducing, or enabling others to sell or pass off any product as a genuine Plaintiff's product or any other product produced by Plaintiff that is not Plaintiff's or not produced under the authority, control, or supervision of Plaintiff and approved by Plaintiff for sale under Plaintiff's trademarks and associated with or derived from Plaintiff's trademarks;

iii. Making, using, selling, and/or importing to the United States for retail sale or resale any products that infringe Plaintiff's Design Patents

iv. Committing any acts calculated to cause consumers to believe that Defendants' counterfeit product is those sold under the authority, control, or supervision of Plaintiff, or are sponsored by, approved of, or otherwise connected with Plaintiff,

including without limitation through use of Plaintiff's original photographs texts in connection with the offer or sale of counterfeit products;

v. Further infringing Plaintiff's trademarks and damaging Plaintiff's goodwill;

vi. Otherwise competing unfairly with Plaintiff in any manner;

vii. Shipping (including drop-shipping), delivering, holding for sale, transferring, or otherwise moving, storing, distributing, returning, or otherwise disposing of, in any manner, products or inventory not manufactured by or for Plaintiff, nor authorized by Plaintiff to be sold or offered for sale, and which bear any Plaintiff's trademarks, or any reproductions, counterfeit copies, or colorable imitations thereof;

viii. Using, linking to, transferring, selling, exercising control over, or otherwise owning the Defendant Internet Stores, or any other domain name or online marketplace account that is being used to sell or is how Defendants could continue to sell counterfeit product;

ix. Operating and/or hosting websites at the Defendant Internet Stores of any other domain names registered or operated by Defendants that are involved in the distribution, marketing, advertising, offering for sale, or sale of any product bearing the Plaintiff's trademarks or reproduction, counterfeit copy, or colorable imitation thereof that is not a genuine product or not authorized by Plaintiff to be sold in connection with the Plaintiff's trademarks; and,

x. Registering any additional domain names that use or incorporate any portion of the Plaintiff's trademarks; and,

B. That Defendants, their affiliates, officers, agents, servants, employees, attorneys, confederates, and all persons acting for, with, by through, under, or in active concert with them be temporarily, preliminarily, and permanently enjoined and restrained from:

i. Displaying images protected by the Plaintiff's trademarks in connection with the distribution, advertising, offer for sale and/or sale of any product that is not a genuine product of Plaintiff's or is not authorized by Plaintiff to be sold in connection with the Plaintiff's trademarks; and

ii. Shipping, delivering, holding for same, distributing, returning, transferring, or otherwise moving, storing, or disposing of in any manner products or inventory not manufactured by or for Plaintiff, not authorized by Plaintiff to be sold or offered for sale, and protected by the Plaintiff's Trademarks or any reproductions, counterfeit copies, or colorable imitation thereof; and,

C. That Defendants, within fourteen (14) days after service of judgment with notice of entry thereof upon them, be required to file with the Court and serve upon Plaintiff a written report under oath setting forth in detail the manner and form in which Defendants have complied with any and all injunctive relief ordered by this Court;

D. Entry of an Order that, upon Plaintiff's request, those in privity with Defendants and those with notice of the injunction, including any online marketplaces such as: Amazon and Alibaba Group Holding Ltd., DHgate, eBay, Etsy, Joom, Shopify, Walmart, Wish, Alipay.com Co., Ltd. and any related Alibaba entities (collectively "Alibaba");; payment processors such as PayPal, Stripe, Payoneer; social media platforms such as: Facebook, YouTube, LinkedIn, Twitter; Internet search engines such as Google, Bing, and Yahoo; webhosts for the Defendants Domain Names, and domain name registrars, that are provided with notice of the injunction, cease

facilitating access to any or all webstores through which Defendants engage in the sale of counterfeit products using the Plaintiff's trademarks; shall:

i. Disable and cease providing services for any accounts through which Defendants engage in the sale of counterfeit Plaintiff's PUFFIN and FUN.TOGETHER. branded product using Plaintiff's trademarks, including any accounts associated with the Defendants listed on Schedule A;

ii. Disable and cease displaying any advertisements used by or associated with Defendants in connection with the sale of counterfeiting and infringing counterfeit product using Plaintiff's trademarks; and,

iii. Take all steps necessary to prevent links to the Defendant Online Stores identified in Schedule A from displaying in search results, including, but not limited to, removing links to the Defendant Online stores from any search index; and,

E. That each Defendant account for and pay to Plaintiff all profits realized by Defendants by reason of Defendants' unlawful acts herein alleged, and that the amount of damages for infringement of Plaintiff's trademarks be increased by a sum not exceeding three times the amount thereof as provided by 15 U.S.C. § 1117;

F. For Judgment in favor of Plaintiff against Defendants that they have: (a) willfully infringed Plaintiff's trademarks in its federally registered trademarks pursuant to 15 U.S.C. § 1114; and (b) otherwise injured the business reputation and business of Plaintiff by Defendants' acts and conduct set forth in this Complaint;

G. For Judgment in favor of Plaintiff against Defendants for actual damages or statutory damages pursuant to 15 U.S.C. § 1117, at the election of Plaintiffs, in an amount to be determined at trial;

H. In the alternative, that Plaintiff be awarded statutory damages pursuant to 15 U.S.C. § 1117(c)(2) of \$2,000,000 for each and every use of Plaintiff's Trademarks;

I. That Defendants, their affiliates, officers, agents, servants, employees, attorneys, confederates, and all persons acting for, with, by, through, under or in active concert with them be temporarily, preliminarily, and permanently enjoined and restrained from:

- i. making, using, offering for sale, selling, and/or importing into the United States for subsequent sale or use any products not authorized by Plaintiff and that include any reproduction, copy or colorable imitation of the design claimed in the Puffin Designs;
- ii. aiding, abetting, contributing to, or otherwise assisting anyone in infringing upon the Puffin Designs; and
- iii. effecting assignments or transfers, forming new entities or associations or utilizing any other device for the purpose of circumventing or otherwise avoiding the prohibitions set forth in Subparagraphs (a) and (b).

J. Entry of an Order that, upon Plaintiff's request, those with notice of the injunction, including, without limitation, any online marketplace platforms such as Amazon and Alibaba Group Holding Ltd., DHgate, eBay, Etsy, Joom, Shopify, Walmart, Wish, Alipay.com Co., Ltd. and any related Alibaba entities (collectively "Alibaba"); payment processors such as PayPal, Stripe, Payoneer; social media platforms such as: Facebook, YouTube, LinkedIn, Twitter; Internet search engines such as Google, Bing, and Yahoo; webhosts for the Defendants Domain Names, and domain name registrars shall disable and cease displaying any advertisements used by or associated with Defendants in connection with the sale of goods that infringe the ornamental design claimed in the Puffin Designs;

K. That Plaintiff be awarded such damages as it shall prove at trial against Defendants that are adequate to compensate Plaintiff for Defendants' infringement of Plaintiff's Designs, but in no event less than a reasonable royalty for the use made of the invention by the Defendants, together with interest and costs, pursuant to 35 U.S.C. § 284;

L. That the amount of damages awarded to Plaintiff to compensate Plaintiff for infringement of the Puffin Designs be increased by three times the amount thereof, as provided by 35 U.S.C. § 284;

M. In the alternative, that Plaintiff be awarded complete accounting of all revenue and profits realized by Defendants from Defendants' infringement of the Puffin Designs, pursuant to 35 U.S.C. § 289;

N. That Defendants, their affiliates, officers, agents, employees, attorneys, and all persons acting for, with, by, through, under, or in active concert with them be temporarily, preliminarily, and permanently enjoined and restrained from:

i. using the PUFFIN Works or any reproductions, copies, or colorable imitations thereof in any manner with the distribution, marketing, advertising, offering for sale, or sale of any product that is not an authorized PUFFIN Products or is not authorized by Plaintiff to be sold in connection with the PUFFIN Works;

ii. passing off, inducing, or enabling others to sell or pass off any product or not produced under the authorization, control, or supervision of Plaintiff and approved by Plaintiff for sale under the PUFFIN Works;

iii. further infringing the PUFFIN Works and damaging Plaintiff's goodwill;

iv. shipping, delivering, holding for sale, transferring or otherwise moving, storing, distributing, returning, or otherwise disposing of, in any manner, products or

inventory not authorized by Plaintiff to be sold or offered for sale, and which directly use the PUFFIN Works and which are derived from Plaintiff's copyrights in the PUFFIN Works; and

v. using, linking to, transferring, selling, exercising control over, or otherwise owning the Defendant Internet Stores, or any other online marketplace account that is being used to sell products or inventory not authorized by Plaintiff which are derived from Plaintiff's copyrights in the PUFFIN Works;

O. Entry of an Order that, upon Plaintiff's request, those in privity with Defendants and those with notice of the injunction, including any online marketplaces such as: Amazon and Alibaba Group Holding Ltd., DHgate, eBay, Etsy, Joom, Shopify, Walmart, Wish, Alipay.com Co., Ltd. and any related Alibaba entities (collectively "Alibaba"); payment processors such as PayPal, Stripe, Payoneer; social media platforms such as: Facebook, YouTube, LinkedIn, Twitter; Internet search engines such as Google, Bing, and Yahoo; webhosts for the Defendants Domain Names, and domain name registrars, that are provided with notice of the injunction, cease facilitating access to any or all webstores through which Defendants engage in the sale of infringing products using the Plaintiff's copyrights; shall:

i. disable and cease providing services for any accounts through which Defendants engage in the sale of products not authorized by Plaintiff which reproduce the PUFFIN Works or are derived from the PUFFIN Works, including any accounts associated with the Defendants listed on Schedule A;

ii. disable and cease displaying any advertisements used by or associated with Defendants in connection with the sale of products not authorized by Plaintiff which are derived from the PUFFIN Works; and

iii. take all steps necessary to prevent links to the Defendant accounts identified on Schedule A from displaying in search results, including, but not limited to, removing links to the Defendant accounts from any search index;

P. For Judgment in favor of Plaintiff against Defendants that they have: a) willfully infringed Plaintiff's rights in her federally registered copyrights pursuant to 17 U.S.C. §501; and b) otherwise injured the business reputation and business of Plaintiff by Defendants' acts and conduct set forth in this Complaint;

Q. For Judgment in favor of Plaintiff against Defendants for actual damages or statutory damages pursuant to 17 U.S.C. §504, at the election of Plaintiff, in an amount to be determined at trial;

R. That Plaintiff be awarded its reasonable attorneys' fees and costs; and,

S. That Plaintiff be awarded any and all other relief that this Court deems equitable and just.

Plaintiff demands trial by jury as to all causes of action so triable.

Dated: October 14, 2022

Respectfully submitted,

/s/ James E. Judge
Zareefa B. Flener (IL Bar No. 6281397)
James E. Judge (IL Bar No. 6243206)
Flener IP Law, LLC
77 W. Washington St., Ste. 800
Chicago, IL 60602
(312) 724-8874
jjudge@fleneriplaw.com